

AIR BEARING SLEWING RINGS

a New Way to approach radial and axial loads

FEATURING:

HIGH SPEED

HIGH PRECISION

NO WEAR

NO OIL

ZERO FRICTION

SILENT AND SMOOTH

NEUWAY[®]
air bearings

Frictionless Motion™

FIXED HOUSING

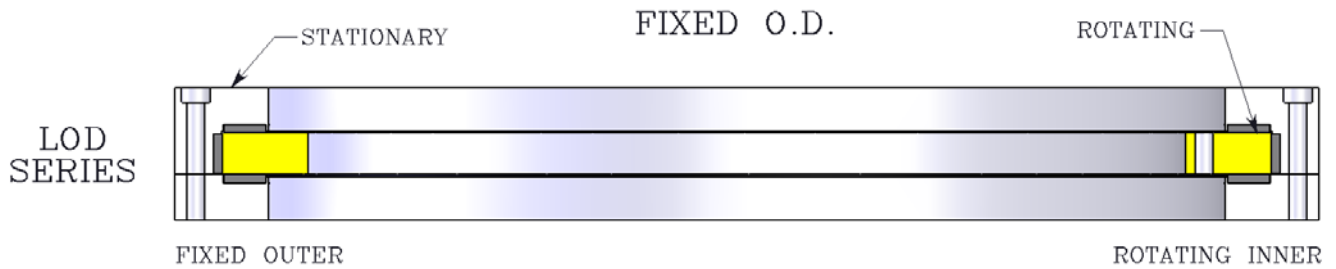
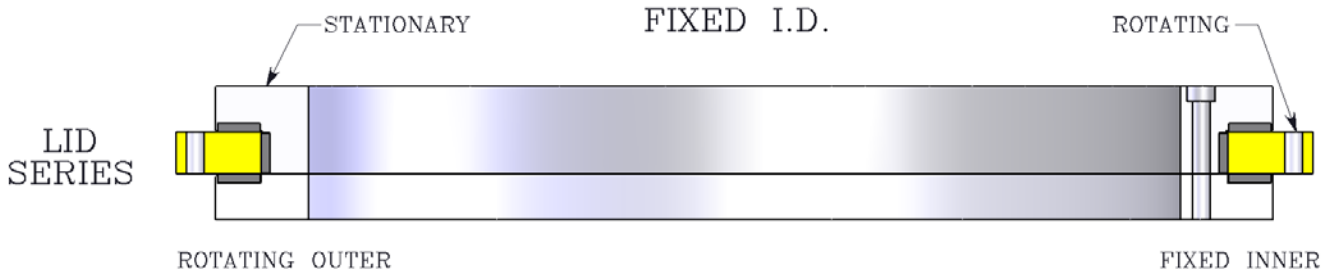

FIXED RING

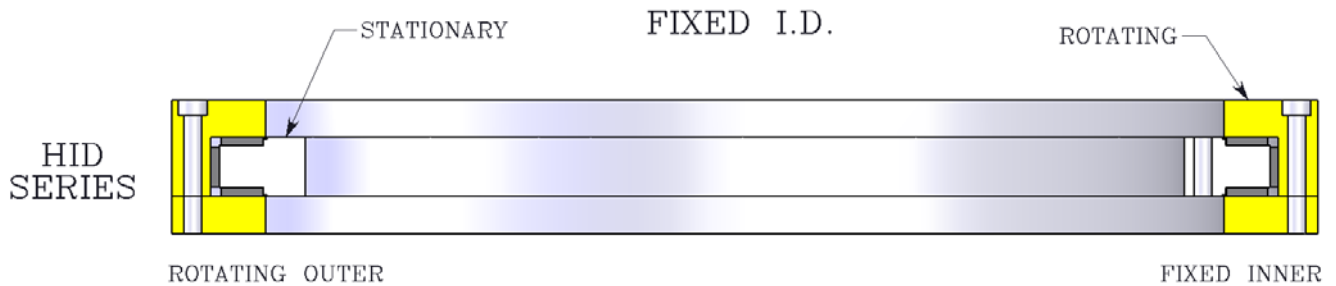
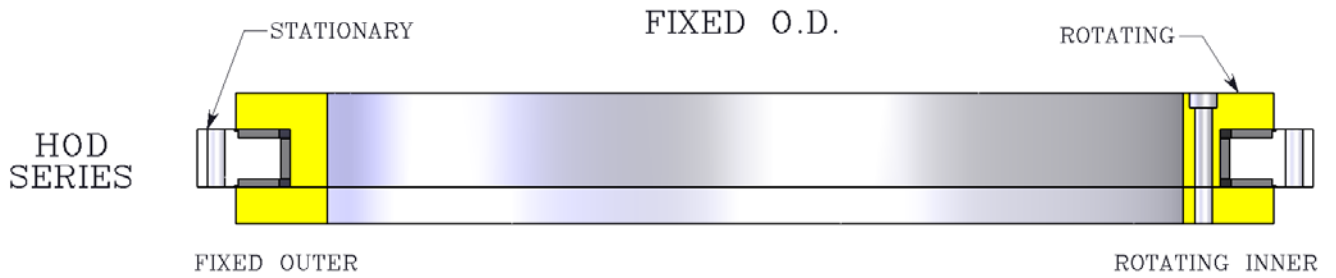

LID SERIES

Fixed Housing – Rotating O.D.

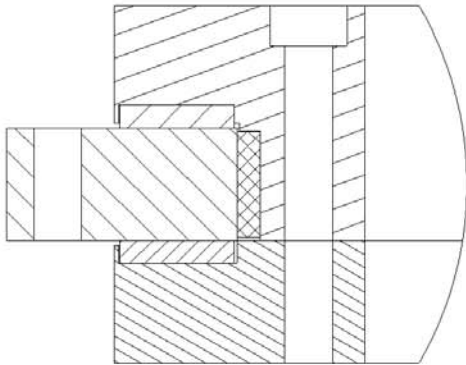

DETAIL B
SCALE 3 : 4

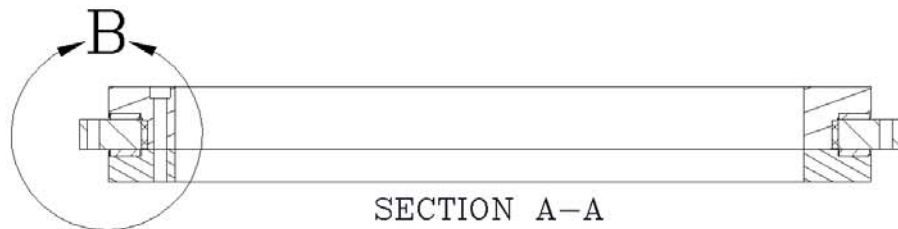
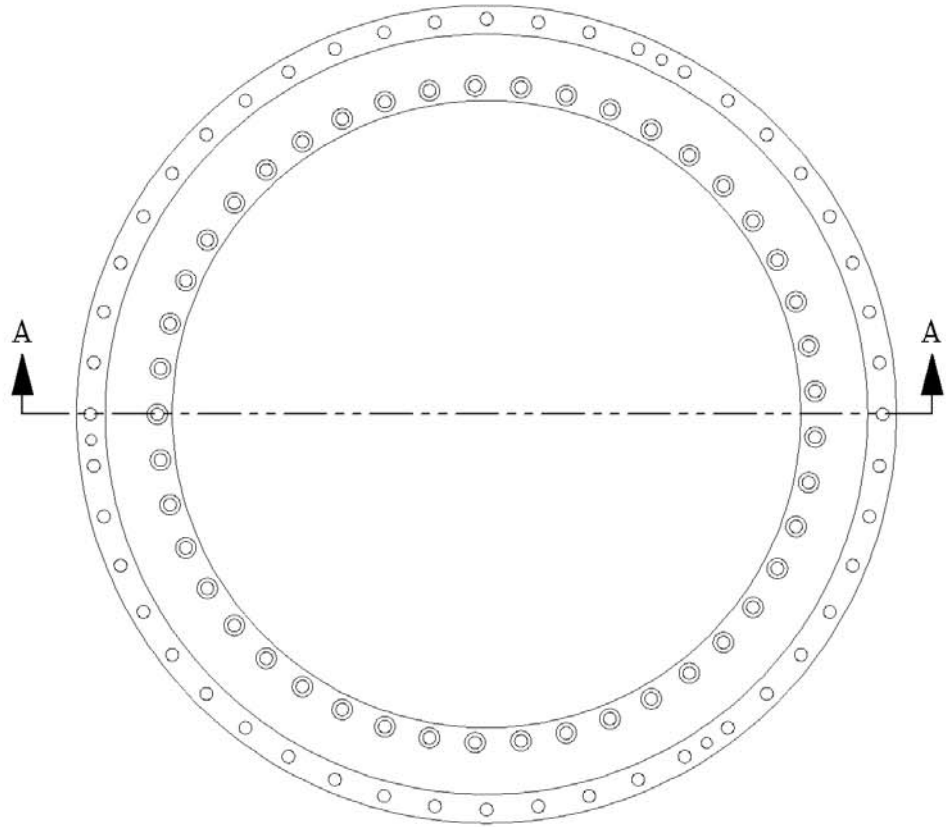
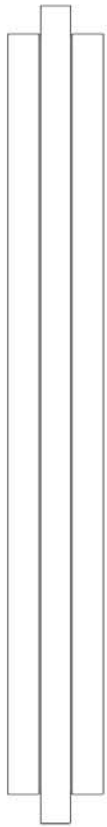
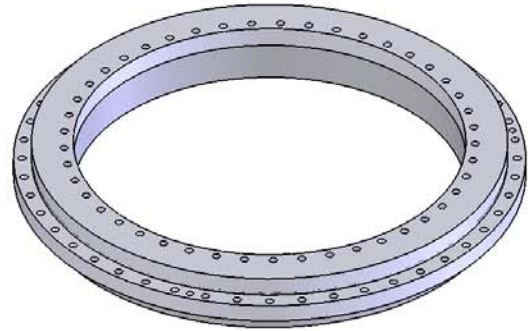

LID SERIES

Specifications



PART NUMBER	DIMENSIONS			LOADING			MAX. SPEED (RPM)
	'D' O.D. (MM)	'd' I.D. (MM)	'H' HEIGHT (MM)	AXIAL IDEAL LOAD (N)	RADIAL IDEAL LOAD (N)	AXIAL AND RADIAL RUNOUT (μM)	
LID-80	146	80	35	1075	320	1	10,500
LID-100	185	100	38	1345	400	1	8,400
LID-120	210	120	40	1610	480	1	7,000
LID-150	240	150	40	2015	600	1	5,600
LID-180	280	180	43	2415	720	2	4,700
LID-200	300	200	45	2685	800	2	4,200
LID-260	385	260	55	3490	1035	2	3,200
LID-325	450	325	60	4360	1295	4	2,600
LID-395	525	395	65	5300	1575	4	2,100
LID-460	600	460	70	6175	1835	4	1,800

NEWWAY[®]
air bearings

New Way Air Bearings 50 McDonald Blvd. Aston, PA 19348 USA 610.494.6700 www.NewWayAirBearings.com