

4

3

2

1

B

B

A

A

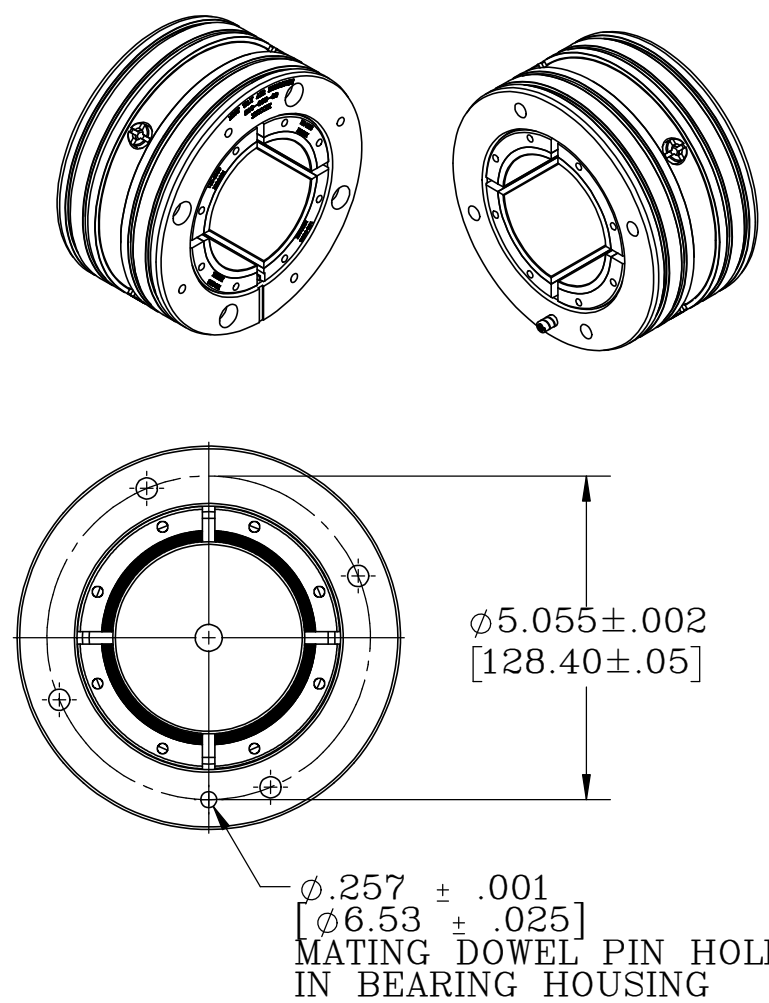
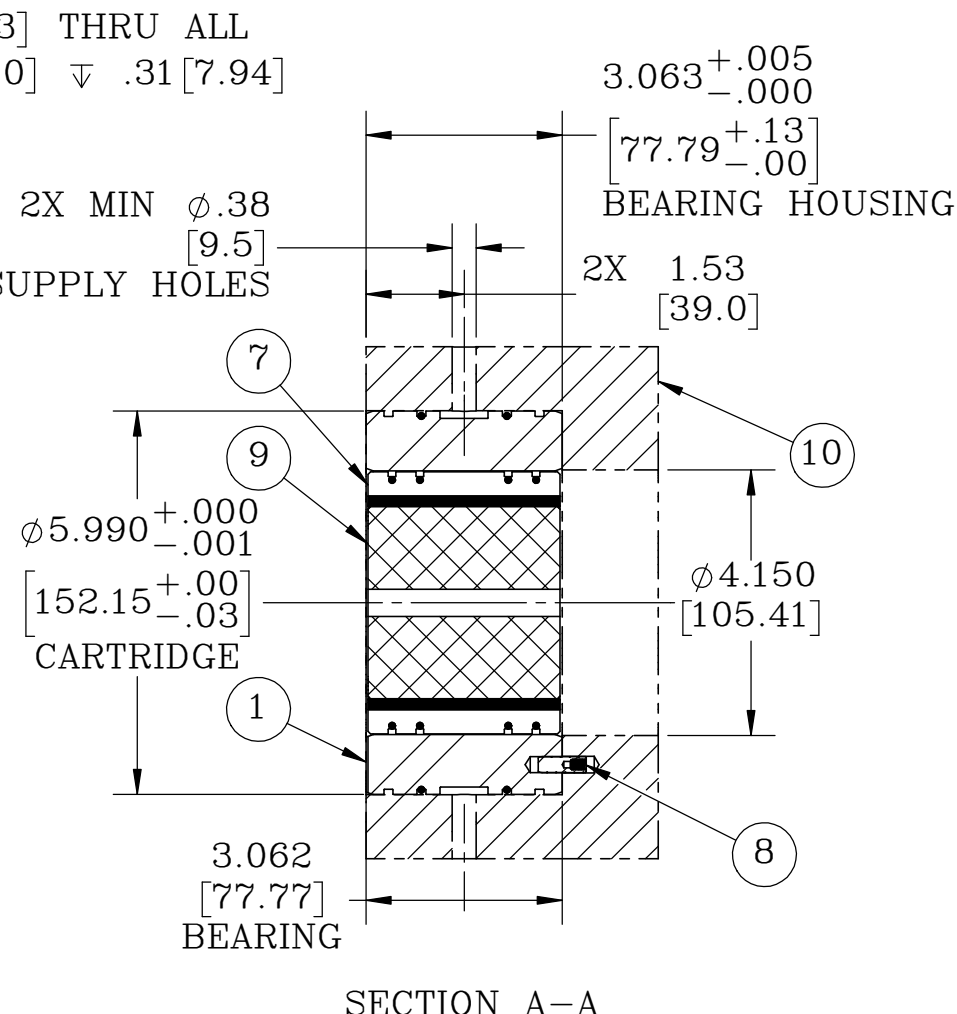
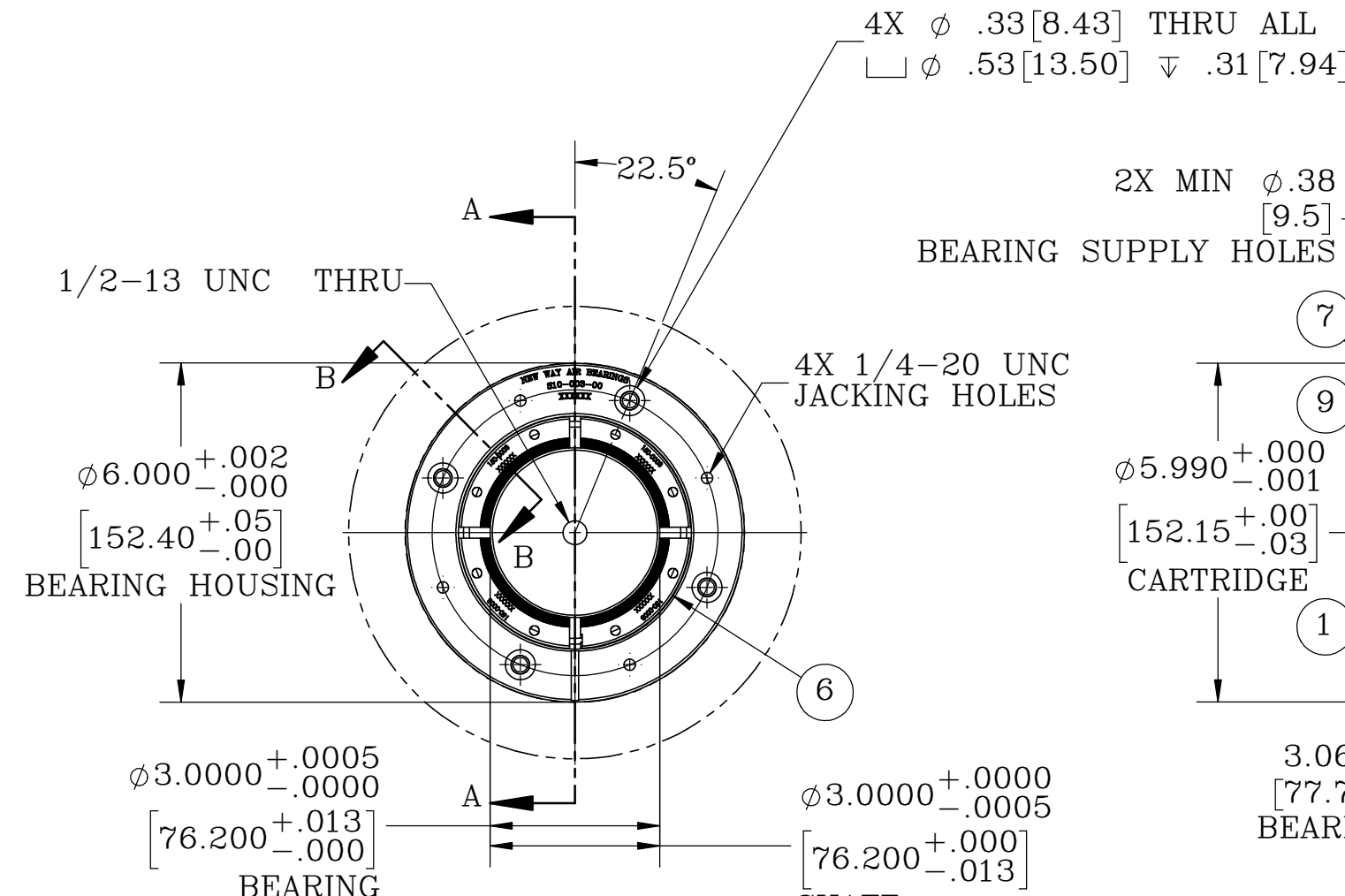

- NOTES:
1. MAXIMUM SPEED IS 20,000 RPM.
 2. SUPPLY PRESSURE OPERATING RANGE 60 - 140 PSIG (413.7 - 965.3 KPA).
 3. MAXIMUM CAPACITY AT 140 PSIG (965.3 KPA) AND 20,000 RPM IS 126 LBF (560.5 N).
 4. TOTAL ESTIMATED FLOW CONSUMPTION OVER THE RANGE OF SPEED AND LOADING IS 34.5 - 55 SCFH (15.4 - 24.6 NLPM) AT 60 PSIG (413.7 KPA) WITH AIR AS THE WORKING GAS.
 5. MAXIMUM OPERATING TEMPERATURE IS 212°F (100°C).
 6. BOTH ENDS OF BEARING ASSEMBLY MUST BE VENTED TO GAUGE PRESSURE.
 7. SHAFT RUNNING SURFACE TO HAVE A FINISH OF 16 RA MICRINCHES (0.4 RA MICROMETERS) OR BETTER.
 8. FOUR 5/16"-18 UNC, 3-1/4" LONG STAINLESS STEEL SOCKET HEAD CAP SCREWS (NOT INCLUDED) ARE USED TO BOLT THE BEARING TO THE BEARING HOUSING. BEARING HOUSING REQUIRES FOUR 5/16"-18 UNC THREADED HOLES EVENLY SPACED ON A ϕ 5.055 B.C. (128.4MM) AT A 22.5° OFFSET FROM VERTICAL, 0.75" (19MM) MINIMUM THREAD DEPTH.
 9. TEMPERATURE DETECTOR (RTD) LOCATED IN ONE BOTTOM PAD. LEADS CAN BE ROUTED THRU VERTICAL GROOVE IN BOTTOM OF THE CARTRIDGE.

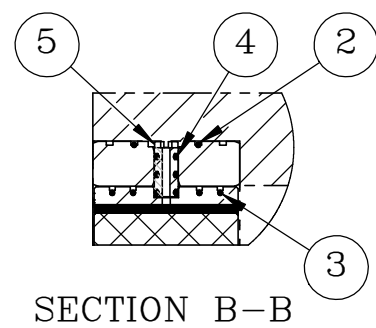

ITEM NO.	PART NUMBER	DESCRIPTION	MATERIAL	QTY
10	CUSTOMER	BEARING HOUSING	CUSTOMER SPECIFIED	1
9	80-00671	3 INCH STANDARD RADIAL BEARING DUMMY SHAFT	NYLON 6/6	1
8	90-0441	DOWEL PIN, VENTED	18-8 SS	1
7	150-0003	RADIAL BEARING ASSEMBLY	316SS/GRAPHITE	3
6	150-0003-1	RADIAL BEARING ASSEMBLY - RTD	316SS/GRAPHITE	1
5	80-00638	STANDARD RADIAL BEARING AIR TRANSFER TUBE	17-4PH H900 SS	4
4	90-0591	2-109 O-RING, .103 WIDE X 0.299 ID	VITON 75A	12
3	90-0618	2-154 O-RING, .103 WIDE X 3.737 ID	VITON 75A	4
2	90-0619	2-162 O-RING, .103 WIDE X 5.737 ID	VITON 75A	2
1	80-00670	3 INCH STANDARD RADIAL BEARING CARTRIDGE - FIXED	316 SS	1

TOLERANCES UNLESS OTHERWISE SPECIFIED:
 ANGLES: ± 1/2°
 DECIMALS: XX ± .01
 FRACTIONS: ± 1/64
 SURFACE ROUGHNESS: Rms MAX.
 BREAK ALL SHARP EDGES: .005-.020

3 INCH STANDARD RADIAL BEARING

NEWWAY®
air bearings

CUSTOMER

NW-RB-03-01-C

CUSTOMER PRINT

4

3

2

1

PROPRIETARY ITEM:
 THIS DRAWING CONTAINS INFORMATION PROPRIETARY TO NEW WAY MACHINE COMPONENTS, INC. ANY REPRODUCTION, DISCLOSURE, OR USE OF THIS DRAWING OR THE INFORMATION CONTAINED HEREIN IS EXPRESSLY PROHIBITED EXCEPT AS NEW WAY MAY OTHERWISE AGREE TO IN WRITING. ALL RIGHTS RESERVED BY NEW WAY MACHINE COMPONENTS, INC.