

4

3

2

1

B

B

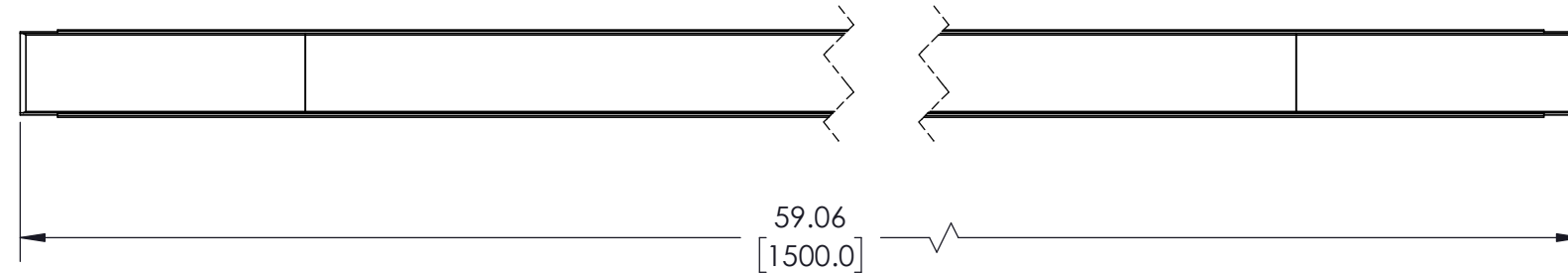
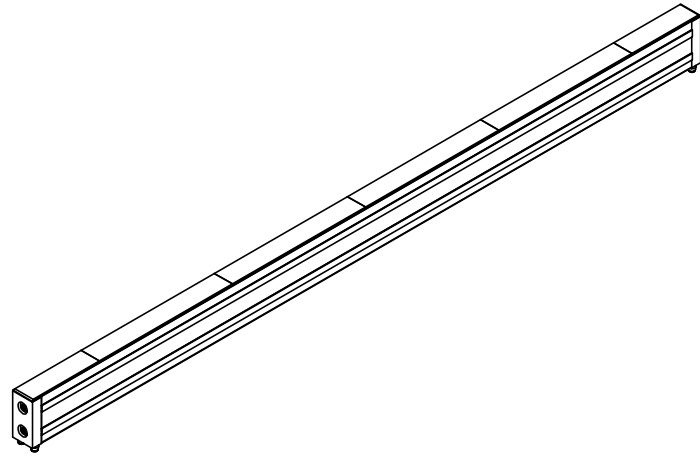

$\square$  .006" (.15mm)

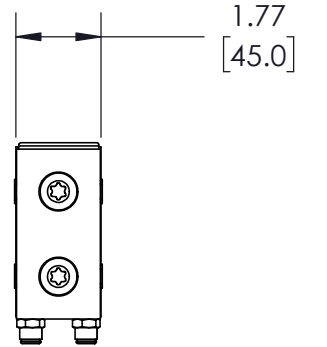

4X REMOVEABLE PLASTIC T-SLOT COVERS

4X 6mm TUBE X G 1/8 FITTING

NOTES:

1. MATERIALS:
  - a. POROUS MEDIA: GRAPHITE
  - b. HOUSING: 6063-T6 ALUMINUM
  - c. END-CAPS: 6061-T6 ALUMINUM
2. FINISHES (PER MIL-A-8625 TYPE 2):
  - a. HOUSING: CLEAR ANODIZE
  - b. END-CAPS: BLACK ANODIZE

PROPRIETARY ITEM:  
THIS DRAWING CONTAINS INFORMATION PROPRIETARY TO NEW WAY MACHINE COMPONENTS, INC. ANY REPRODUCTION, DISCLOSURE, OR USE OF THIS DRAWING OR THE INFORMATION CONTAINED HEREIN IS EXPRESSLY PROHIBITED EXCEPT AS NEW WAY MAY OTHERWISE AGREE TO IN WRITING. ALL RIGHTS RESERVED BY NEW WAY MACHINE COMPONENTS, INC.

TOLERANCES UNLESS OTHERWISE SPECIFIED ANGLES: $\pm 1/2^\circ$ DECIMALS: XX $\pm .01$ XXX $\pm .005$ FRACTIONS: $\pm 1/64$ SURFACE ROUGHNESS: $\sqrt{\text{RMS MAX}}$ BREAK ALL SHARP EDGES: .005-.020	TITLE: 1500mm PA RAIL			
	DRAWN: RSH	DATE: 09/04/19		
	CHECKED:	DATE:	HEAT TREAT:	
	SCALE: 1:4	SHT. 1 OF 1	FINISH: SEE NOTES	
USED ON (NW #): -	EWO. NO.		DWG. NO. S1345PA1500	REV. A

4

3

2

1

A

A