

4

3

2

1

B

B

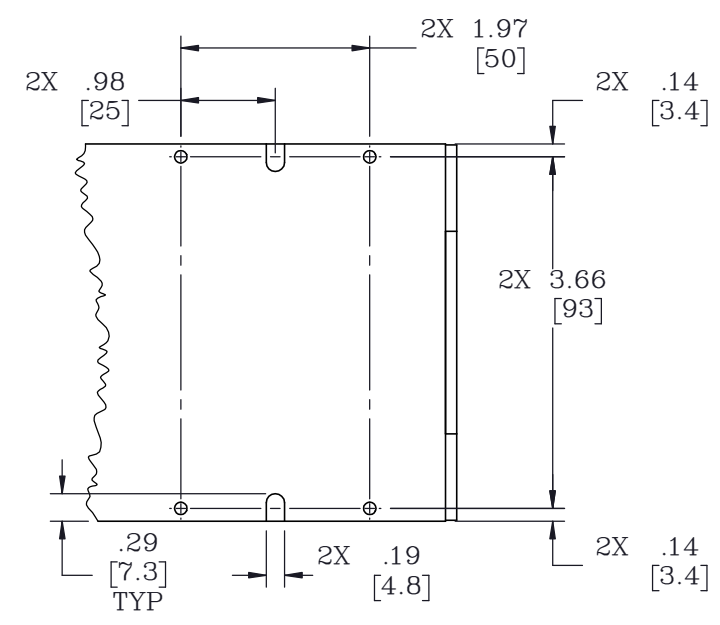
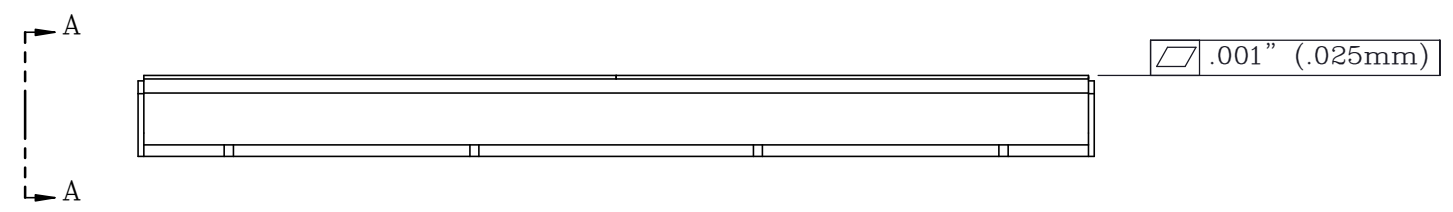
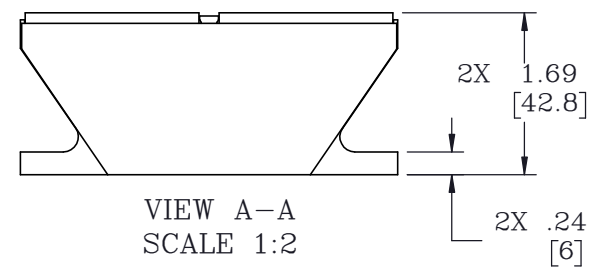
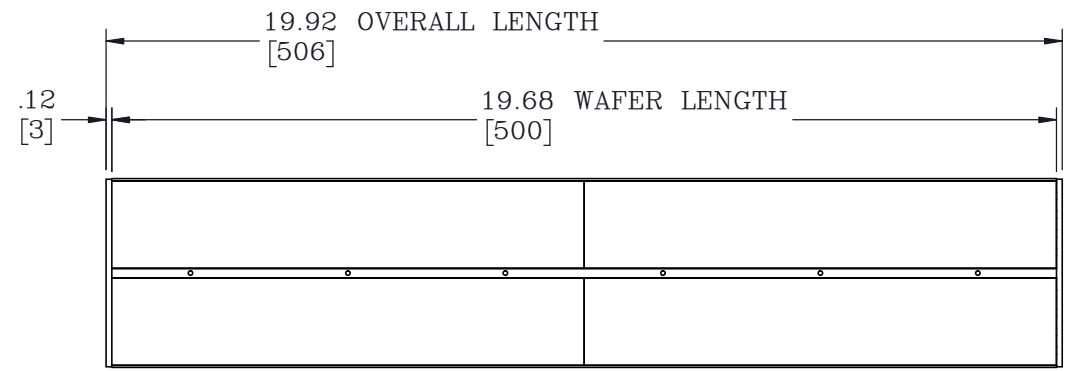

DETAIL A (4X)  
SCALE 1:2

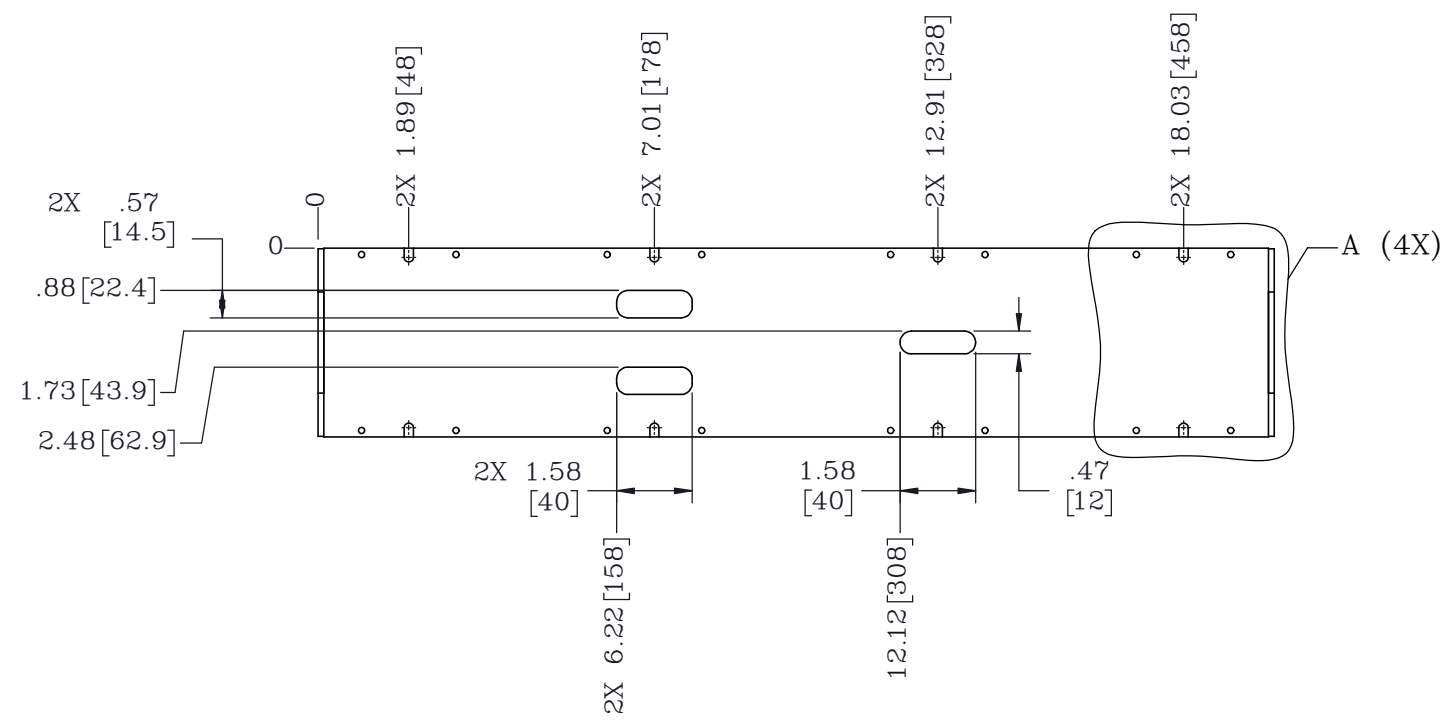

A

A

PROPRIETARY ITEM:  
THIS DRAWING CONTAINS  
INFORMATION PROPRIETARY TO NEW  
WAY MACHINE COMPONENTS, INC. ANY  
REPRODUCTION, DISCLOSURE, OR USE  
OF THIS DRAWING OR THE  
INFORMATION CONTAINED HEREIN  
IS EXPRESSLY PROHIBITED EXCEPT AS  
NEW WAY MAY OTHERWISE AGREE TO  
IN WRITING. ALL RIGHTS RESERVED BY  
NEW WAY MACHINE COMPONENTS, INC.

TOLERANCES UNLESS OTHERWISE SPECIFIED ANGLES: ± 1/2° DECIMALS: XX ± .01 XXX ± .005 FRACTIONS: ± 1/64 SURFACE ROUGHNESS: RMS MAX. BREAK ALL SHARP EDGES: .005-.020	TITLE: 500mm T-SERIES CONVEYOR		 air bearings	
	DRAWN:	DATE: 2/20/19		
	CHECKED:	DATE:	HEAT TREAT: N/A	
	SCALE: 1:4	SHT. 1 OF 1	FINISH: N/A	
USED ON (NW #): N/A	DWG. # S22100T500	REV. -		

4

3

2

1