

4

3

2

1

B

B

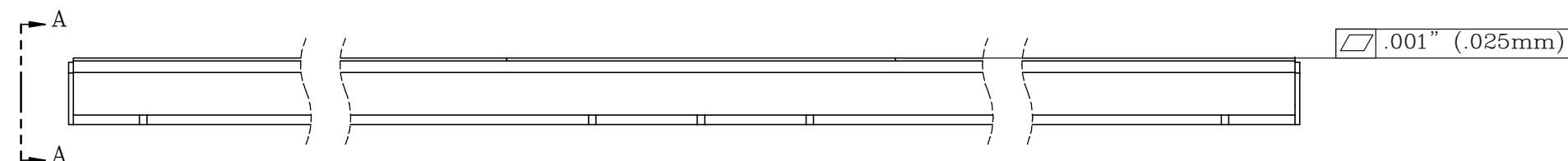
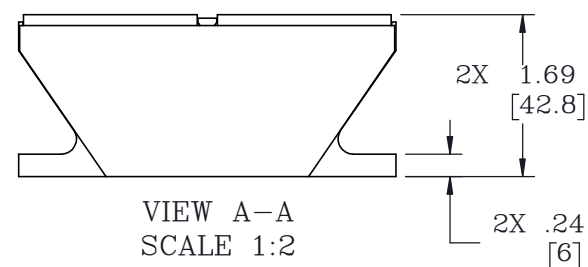
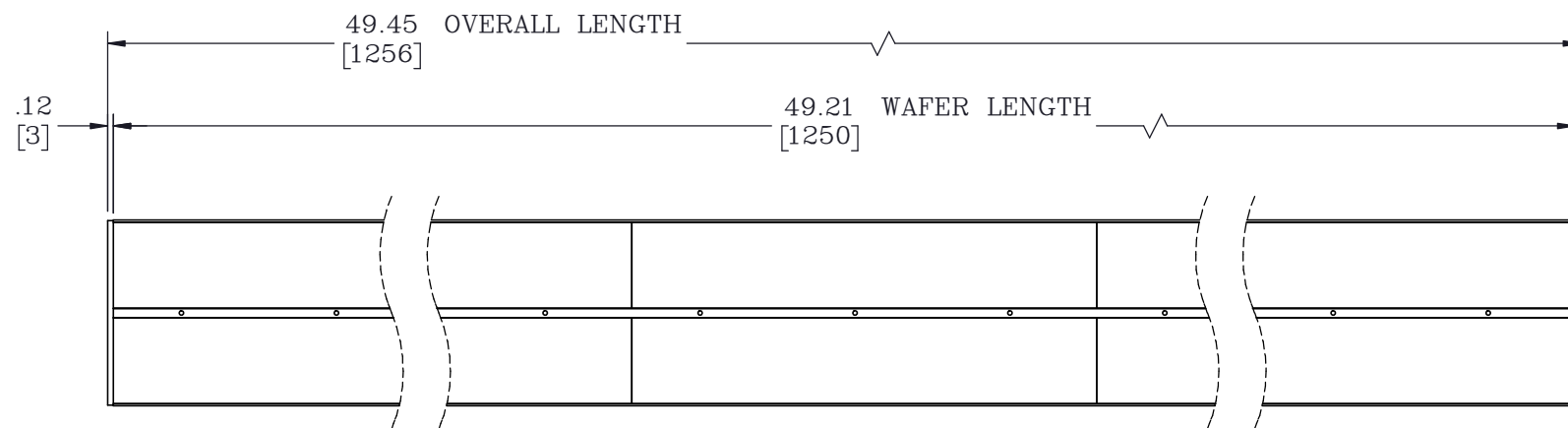

A

A

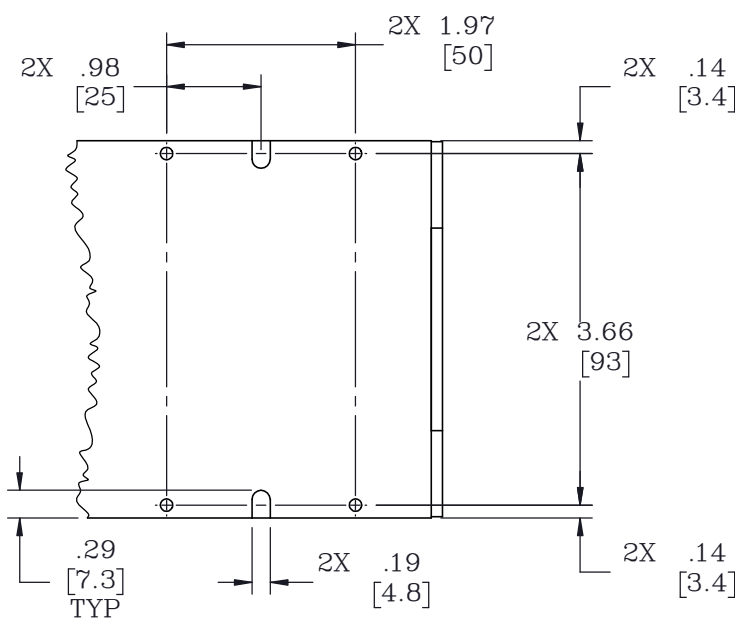

DETAIL A (5X)  
 SCALE 1:2

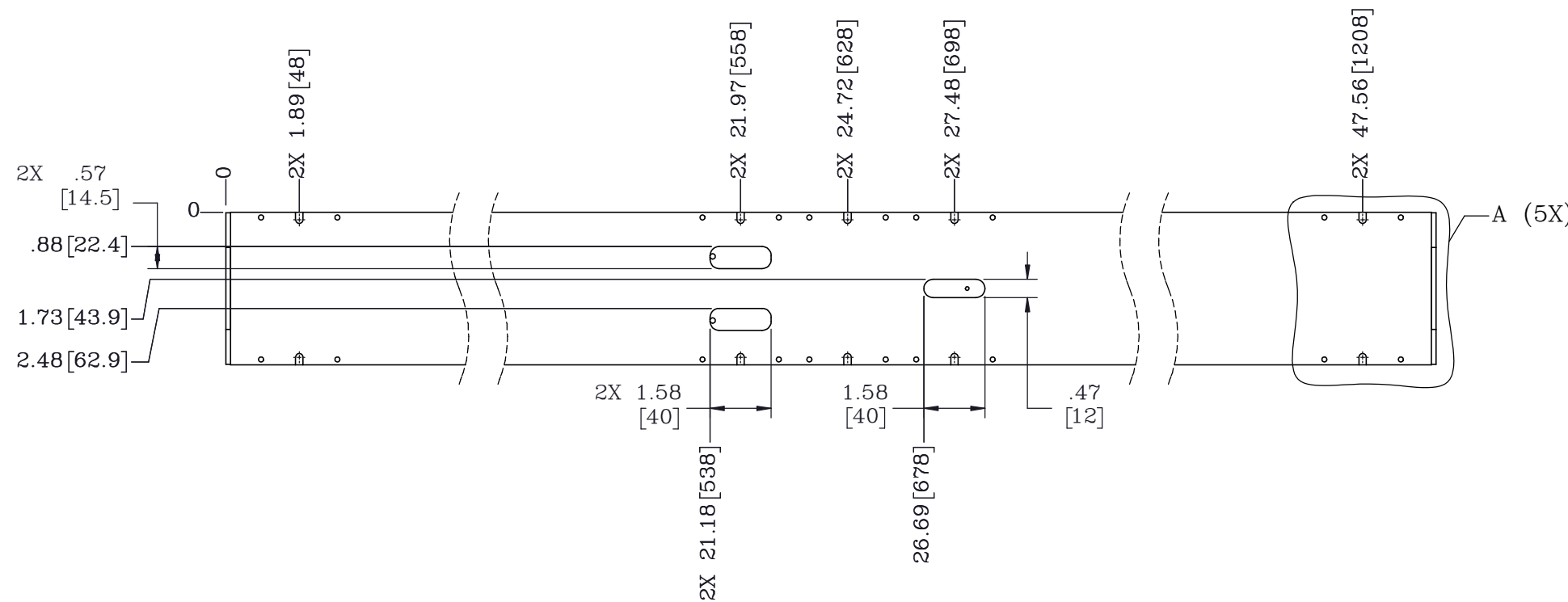

PROPRIETARY ITEM:  
 THIS DRAWING CONTAINS  
 INFORMATION PROPRIETARY TO NEW  
 WAY MACHINE COMPONENTS, INC. ANY  
 REPRODUCTION, DISCLOSURE, OR USE  
 OF THIS DRAWING OR THE  
 INFORMATION CONTAINED HEREIN  
 IS EXPRESSLY PROHIBITED EXCEPT AS  
 NEW WAY MAY OTHERWISE AGREE TO  
 IN WRITING. ALL RIGHTS RESERVED BY  
 NEW WAY MACHINE COMPONENTS, INC.

TOLERANCES UNLESS OTHERWISE SPECIFIED ANGLES: ± 1/2° DECIMALS: XX ± .01 XXX ± .005 FRACTIONS: ± 1/64 SURFACE ROUGHNESS: ∇ RMS MAX. BREAK ALL SHARP EDGES: .005-.020	TITLE: 1250mm T-SERIES CONVEYOR			
	DRAWN:	DATE: 2/20/19		
	CHECKED:	DATE:	HEAT TREAT: N/A	
	SCALE: 1:4	SHT. 1 OF 1	FINISH: N/A	
USED ON (NW #): N/A			DWG. # S22100T1250	REV. -

4

3

2

1