

M30 X .75 EXTERNAL THREAD			
	MAJOR DIA	PITCH DIA	MINOR DIA
MAX	29.978mm	29.491mm	29.166mm
MIN	29.838mm	29.379mm	28.917mm

REVISIONS				
ECN#	REV.	DESCRIPTION	DATE	APPROVED

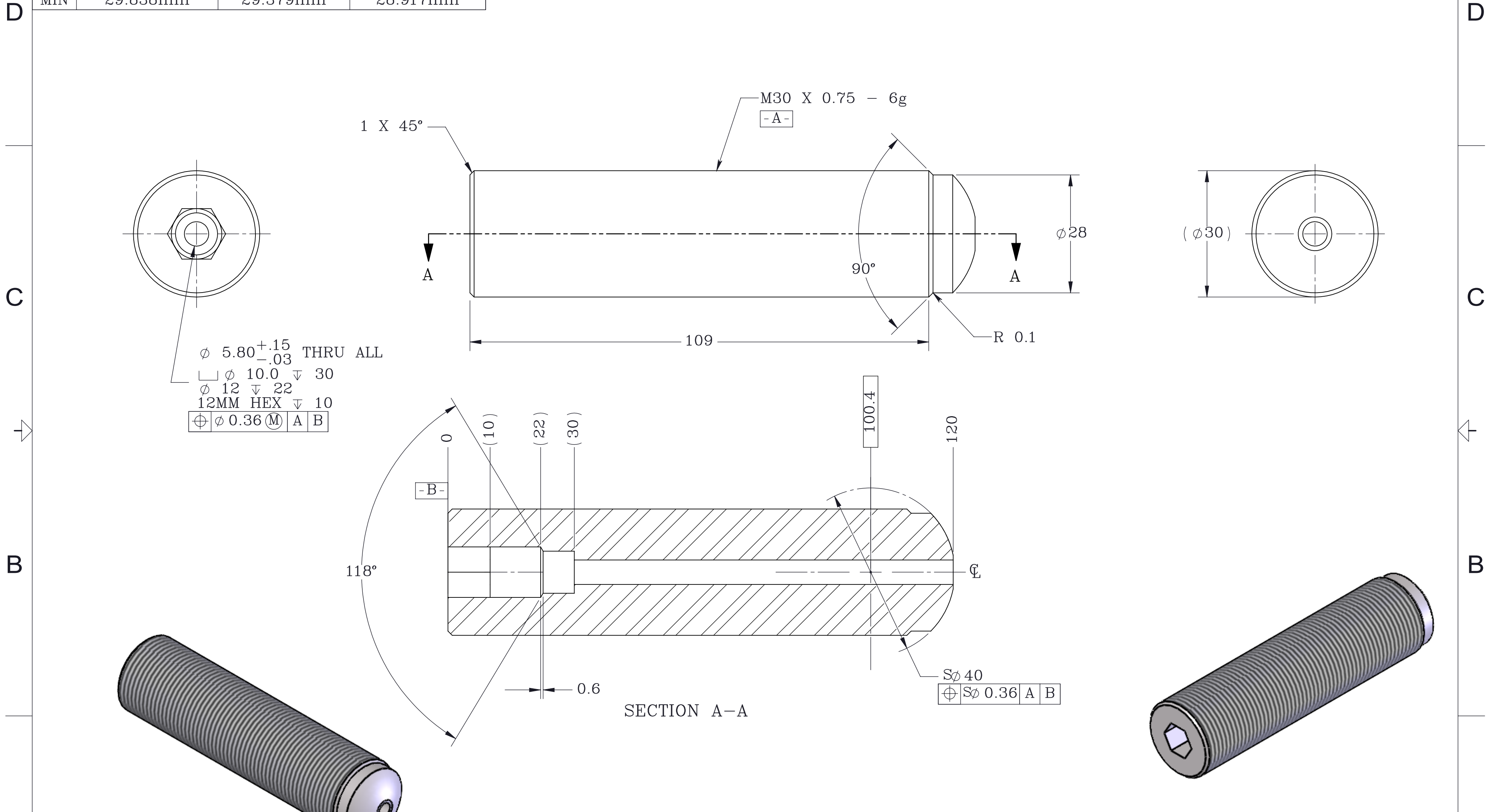

$\phi 5.80^{+.15}_{-.03}$ THRU ALL
 $\perp \phi 10.0 \downarrow 30$
 $\phi 12 \downarrow 22$
 12MM HEX $\downarrow 10$
 $\oplus \phi 0.36 \text{ (M) A B}$

SECTION A-A
 $\phi 40$
 $\oplus \phi 0.36 \text{ A B}$
 100.4
 120
 0.6
 118°
 (10) (22) (30)

PROPRIETARY ITEM:
 THIS DRAWING CONTAINS INFORMATION PROPRIETARY TO NEW WAY MACHINE COMPONENTS, INC. ANY REPRODUCTION, DISCLOSURE, OR USE OF THIS DRAWING OR THE INFORMATION CONTAINED HEREIN IS EXPRESSLY PROHIBITED EXCEPT AS NEW WAY MAY OTHERWISE AGREE TO IN WRITING. ALL RIGHTS RESERVED BY NEW WAY MACHINE COMPONENTS, INC.

TOLERANCES UNLESS OTHERWISE SPECIFIED ANGLES $\pm 1/2^\circ$ DECIMALS X ± 0.2 MM DECIMALS .X ± 0.1 MM SURFACE ROUGHNESS 1.6 $\sqrt{\text{RMS MAX}}$ BREAK ALL SHARP EDGES 0.13-0.50 MM	TITLE: 40MM SD BALL MOUNT M30 X 0.75 THREAD 120MM LONG		NEWWAY [®] air bearings	
	DRAWN: M.P.	DATE: 12/1/2022		
	CHECKED:	DATE:	HEAT TREAT: RH 25-32 C SCALE	DWG. NO.: S8040B01
	SCALE: 1.5:1	SHT. 1 OF 1	FINISH:	REV. -
USED ON: S8040X01	USED ON: S8040X01			REV. -