

4

3

2

1

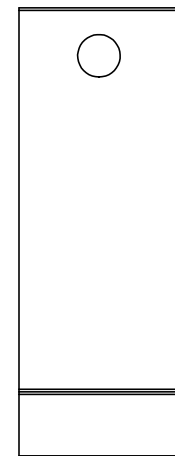
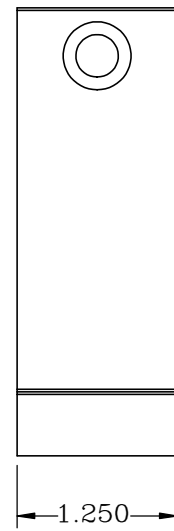
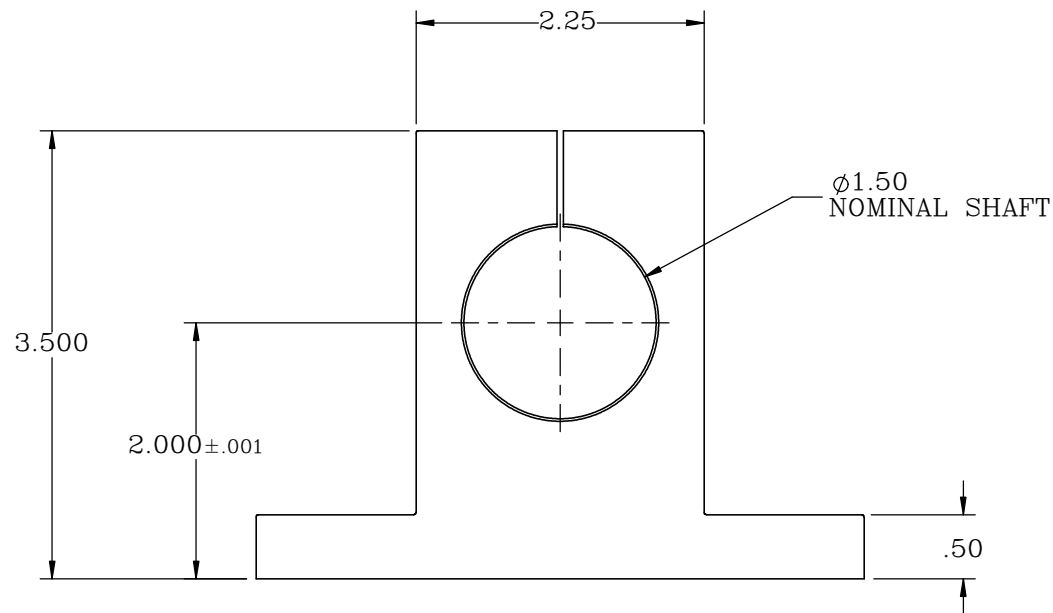
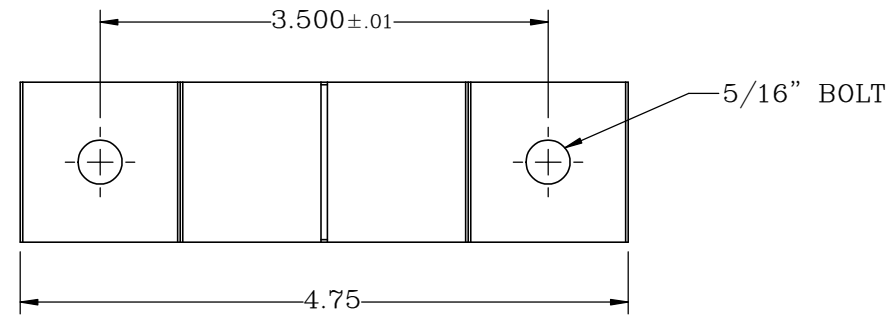
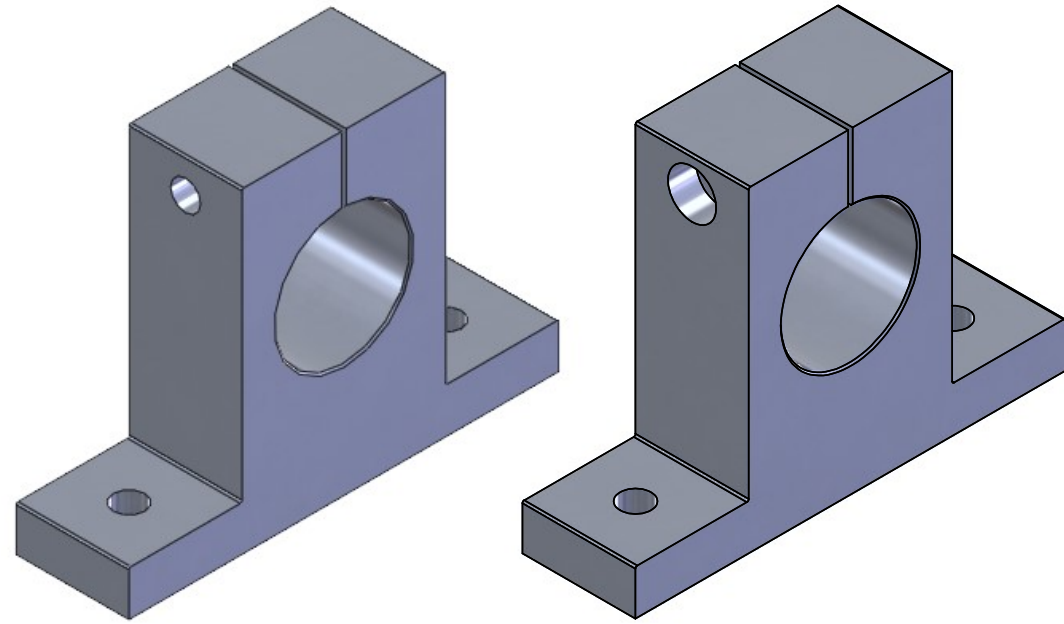

PROPRIETARY ITEM:
 THIS DRAWING CONTAINS
 INFORMATION PROPRIETARY TO NEW
 WAY MACHINE COMPONENTS, INC. ANY
 REPRODUCTION, DISCLOSURE, OR USE
 OF THIS DRAWING OR THE
 INFORMATION CONTAINED HEREIN
 IS EXPRESSLY PROHIBITED EXCEPT AS
 NEW WAY MAY OTHERWISE AGREE TO
 IN WRITING. ALL RIGHTS RESERVED BY
 NEW WAY MACHINE COMPONENTS, INC.

TOLERANCES UNLESS OTHERWISE SPECIFIED ANGLES: ± 1/2° DECIMALS: XX ± .01 XXX ± .005 FRACTIONS: ± 1/64 SURFACE ROUGHNESS: ES/ RMS MAX. BREAK ALL SHARP EDGES: .005-.020	TITLE: 1.5" END MOUNT			
	DRAWN: SAS	DATE: 08/23/21		
	CHECKED: MTS	DATE: 09/24/21	HEAT TREAT: -	
	SCALE: 2:3	SHT. 1 OF 1	FINISH: -	
USED ON (NW #): -			DWG. # S8038E01	REV. -

4

3

2

1

B

B

A

A