

4

3

2

1

REVISIONS				
ECN #	REV.	DESCRIPTION	DATE	APPROVED

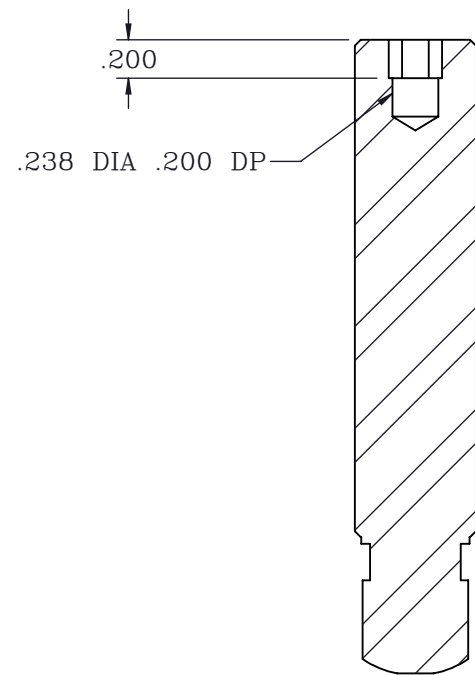
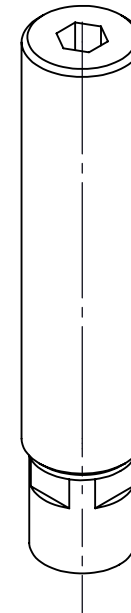
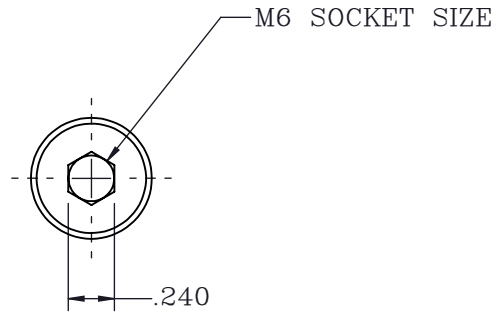

SECTION A-A

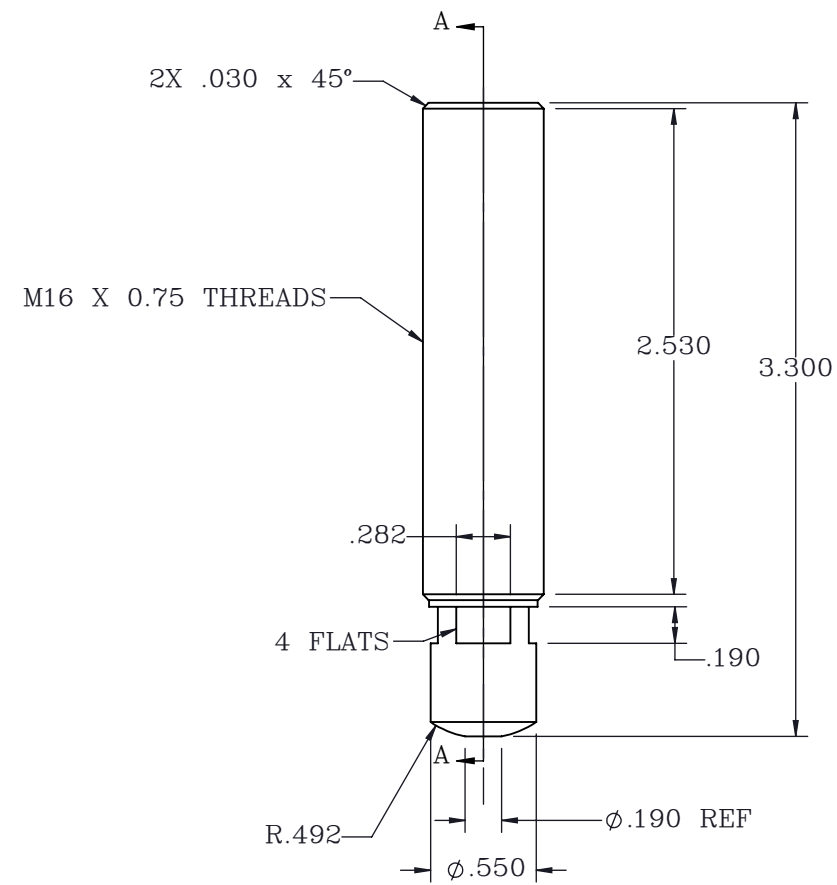

B

B

A

A

PROPRIETARY ITEM:
 THIS DRAWING CONTAINS
 INFORMATION PROPRIETARY TO NEW
 WAY MACHINE COMPONENTS, INC. ANY
 REPRODUCTION, DISCLOSURE, OR USE
 OF THIS DRAWING OR THE
 INFORMATION CONTAINED HEREIN
 IS EXPRESSLY PROHIBITED EXCEPT AS
 NEW WAY MAY OTHERWISE AGREE TO
 IN WRITING. ALL RIGHTS RESERVED BY
 NEW WAY MACHINE COMPONENTS, INC.

TOLERANCES UNLESS OTHERWISE SPECIFIED ANGLES: ± 1/2° DECIMALS: XX ± .01 XXX ± .005 FRACTIONS: ± 1/64 SURFACE ROUGHNESS: √ RMS MAX. BREAK ALL SHARP EDGES: .005-.020	TITLE: 25MM BALL MOUNT, FLAT END			
	DRAWN: ECL	DATE: 7/31/18		
	CHECKED:	DATE:	HEAT TREAT:	EWO. NO.
	SCALE: 1:1	SHT. 1 OF 1	FINISH: NONE	DWG. NO. S8025B05
	USED ON (NW #): NONE	REV. -		

4

3

2

1