

REVISIONS				
ECN #	REV.	DESCRIPTION	DATE	APPROVED
001108	A	REDRAWN AND DIMENSIONED IN SOLID WORKS	11/22/05	KCS

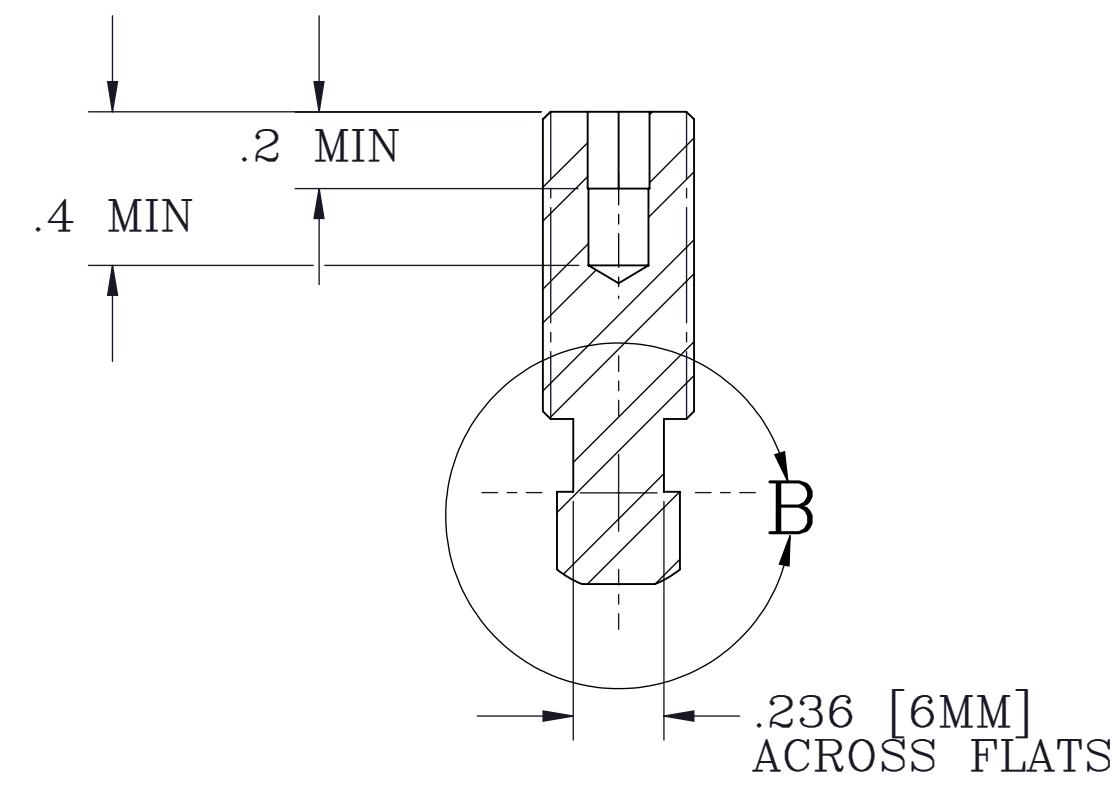

SECTION A-A

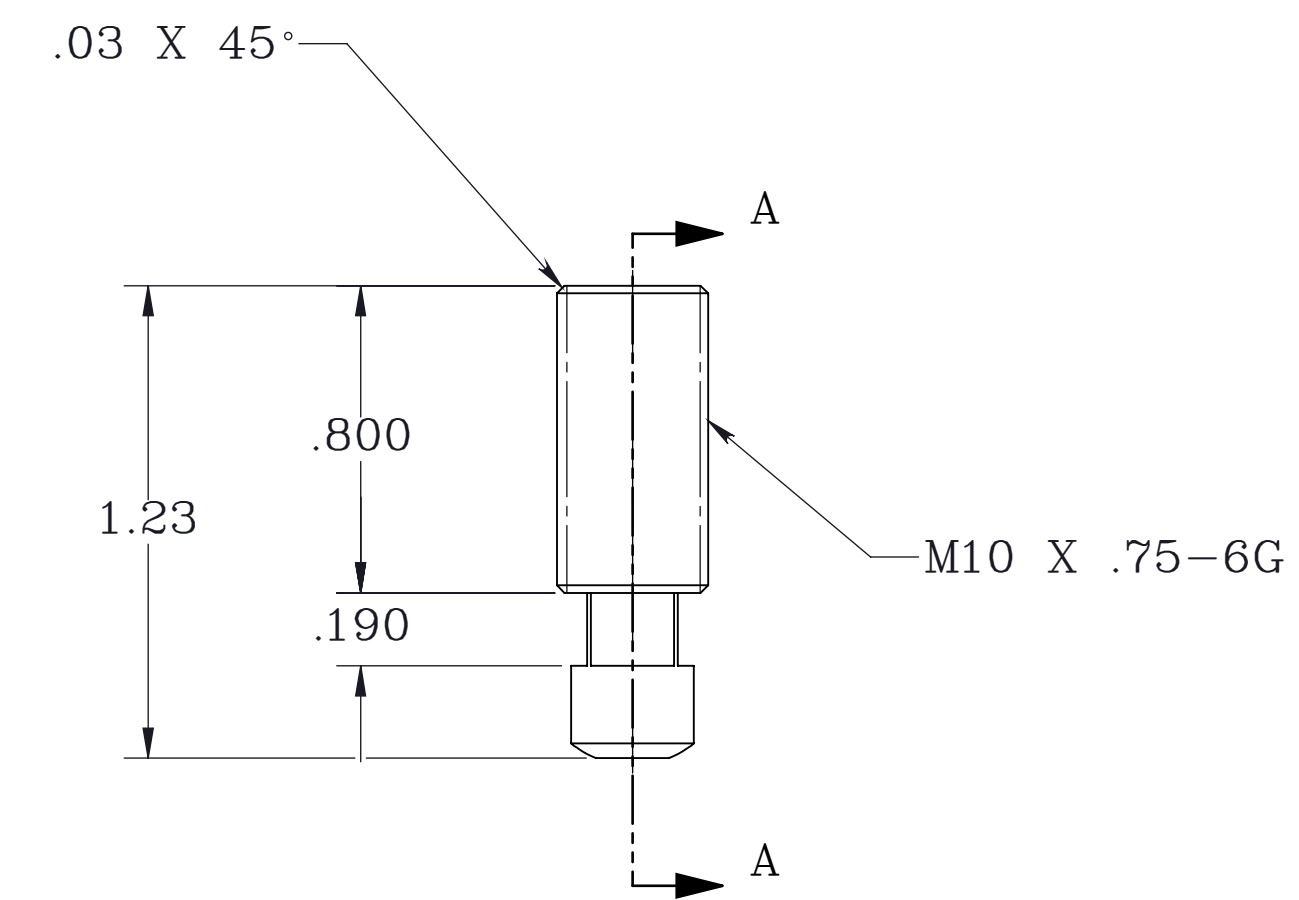
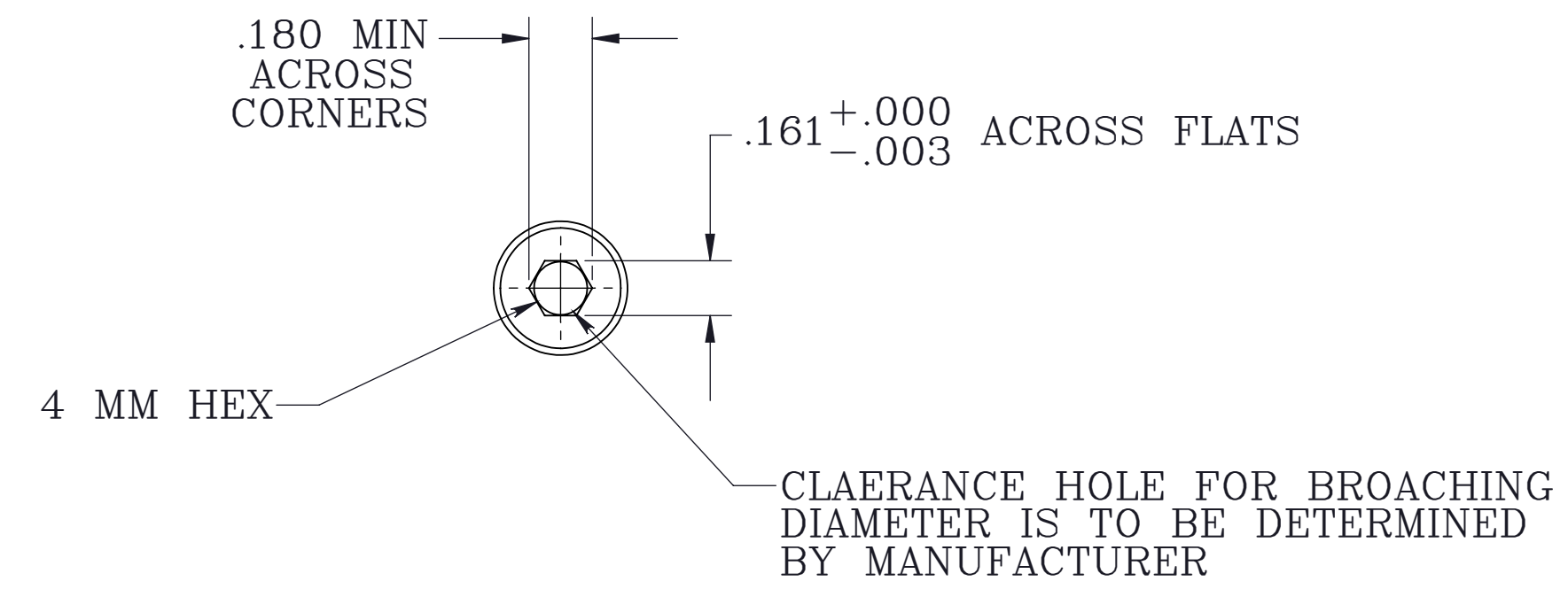
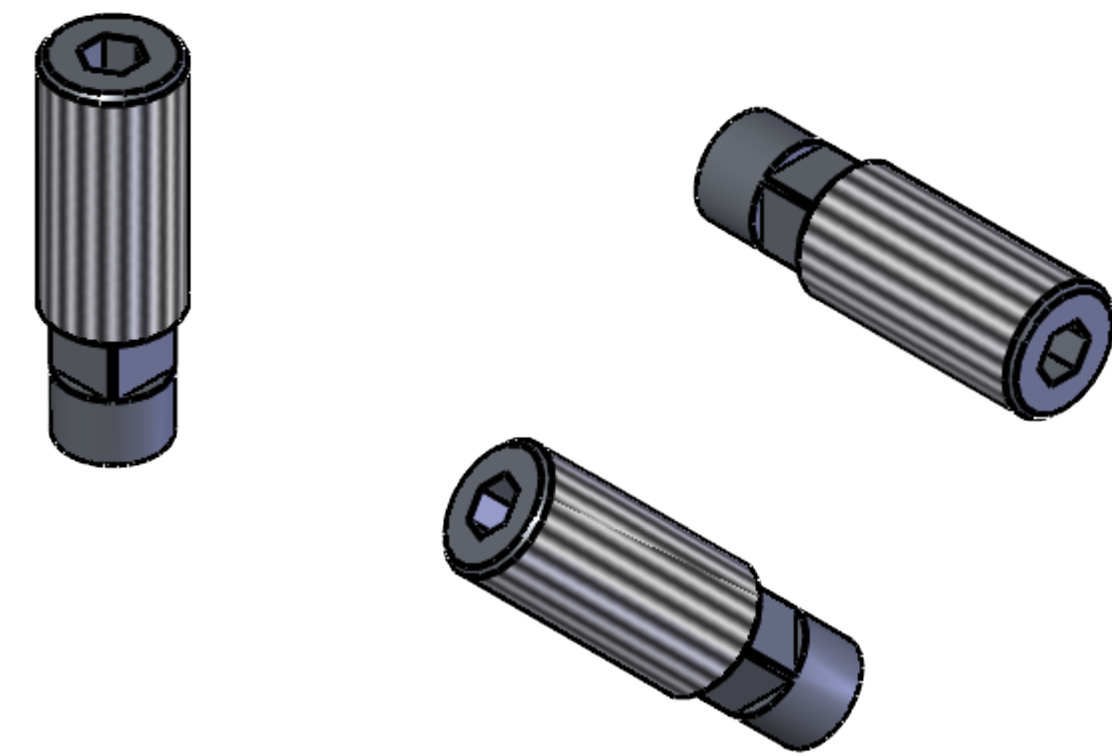
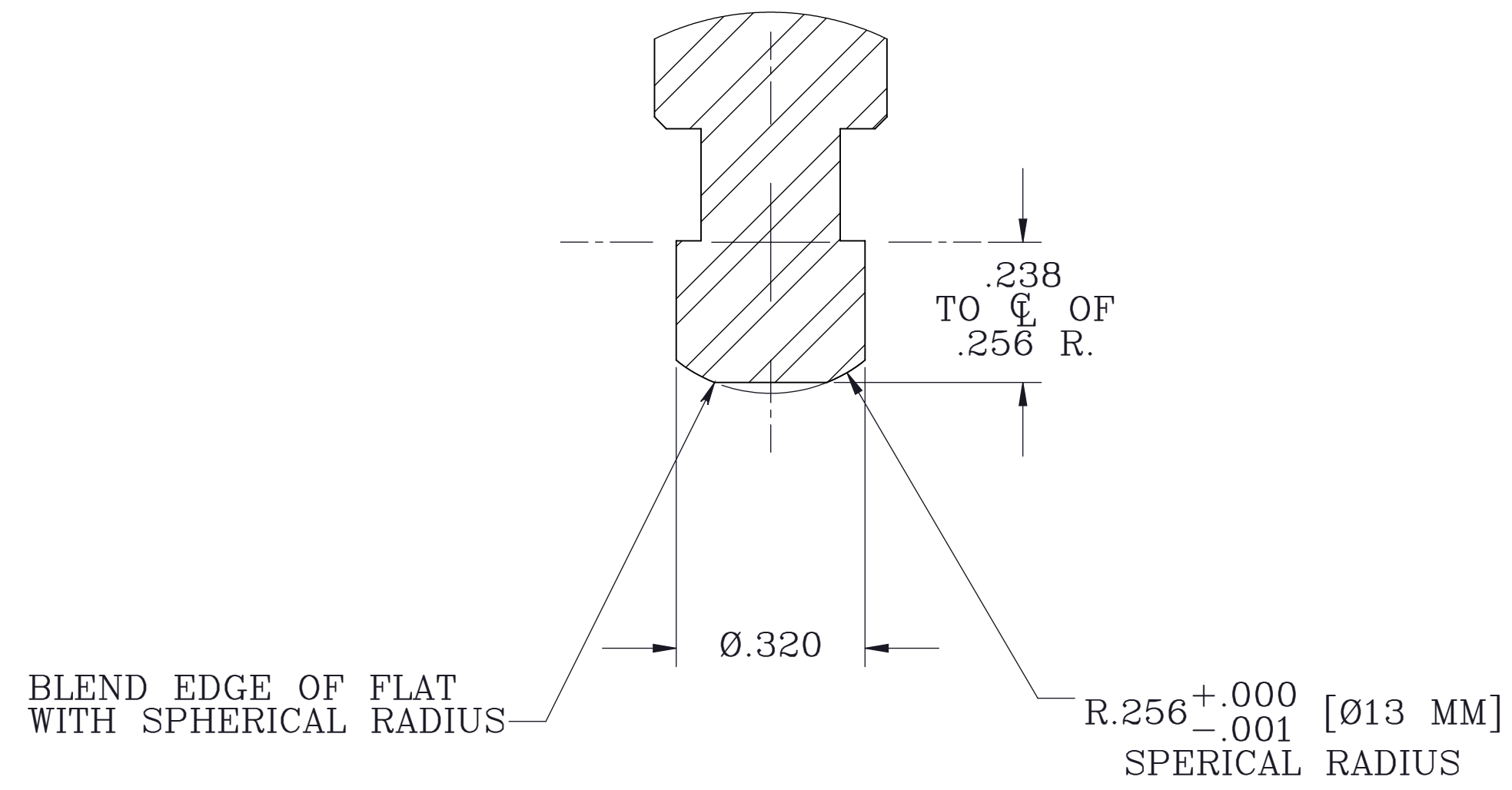

DETAIL B
SCALE 4 : 1

NOTES:

- MATERIAL: 416 STAINLESS STEEL, HEAT TREATED AND COLD FINISHED TO ROCKWELL 'C' 25-32.

PROPRIETARY ITEM:
THIS DRAWING CONTAINS INFORMATION PROPRIETARY TO NEW WAY MACHINE COMPONENTS, INC. ANY REPRODUCTION, DISCLOSURE, OR USE OF THIS DRAWING OR THE INFORMATION CONTAINED HEREIN IS EXPRESSLY PROHIBITED EXCEPT AS NEW WAY MAY OTHERWISE AGREE TO IN WRITING. ALL RIGHTS RESERVED BY NEW WAY MACHINE COMPONENTS, INC.

TOLERANCES UNLESS OTHERWISE SPECIFIED		TITLE: Ø 13 MM BALL MOUNT, M10 X .75 THD.		NEWWAY air bearings	
ANGLES: 1/2°	DECIMALS: .010	DRAWN: KCS	DATE: 12/1/2022		
DECIMALS: .005	FRACTIONS: 1/64	CHECKED:	DATE:	MATERIAL: SEE NOTES	
SURFACE ROUGHNESS: 63 RMS MAX. BREAK ALL SHARP EDGES .005-.020		SCALE: 2:1	SHT: 1 OF 1	HEAT TREAT:	EW. NO.
		USED ON:	FINISH:	DWG. NO. S8013B14	REV. A