

"OAL" GUIDE BAR		STAGE TRAVEL		ASSEMBLY MASS (Kg)
inches	mm "XXX"	inches	mm	
7	178	4	102	1.08
15	381	12	305	1.89

8X .500 SQUARE MOUNTING PAD TYP  
(4X TOP AND BOTTOM)

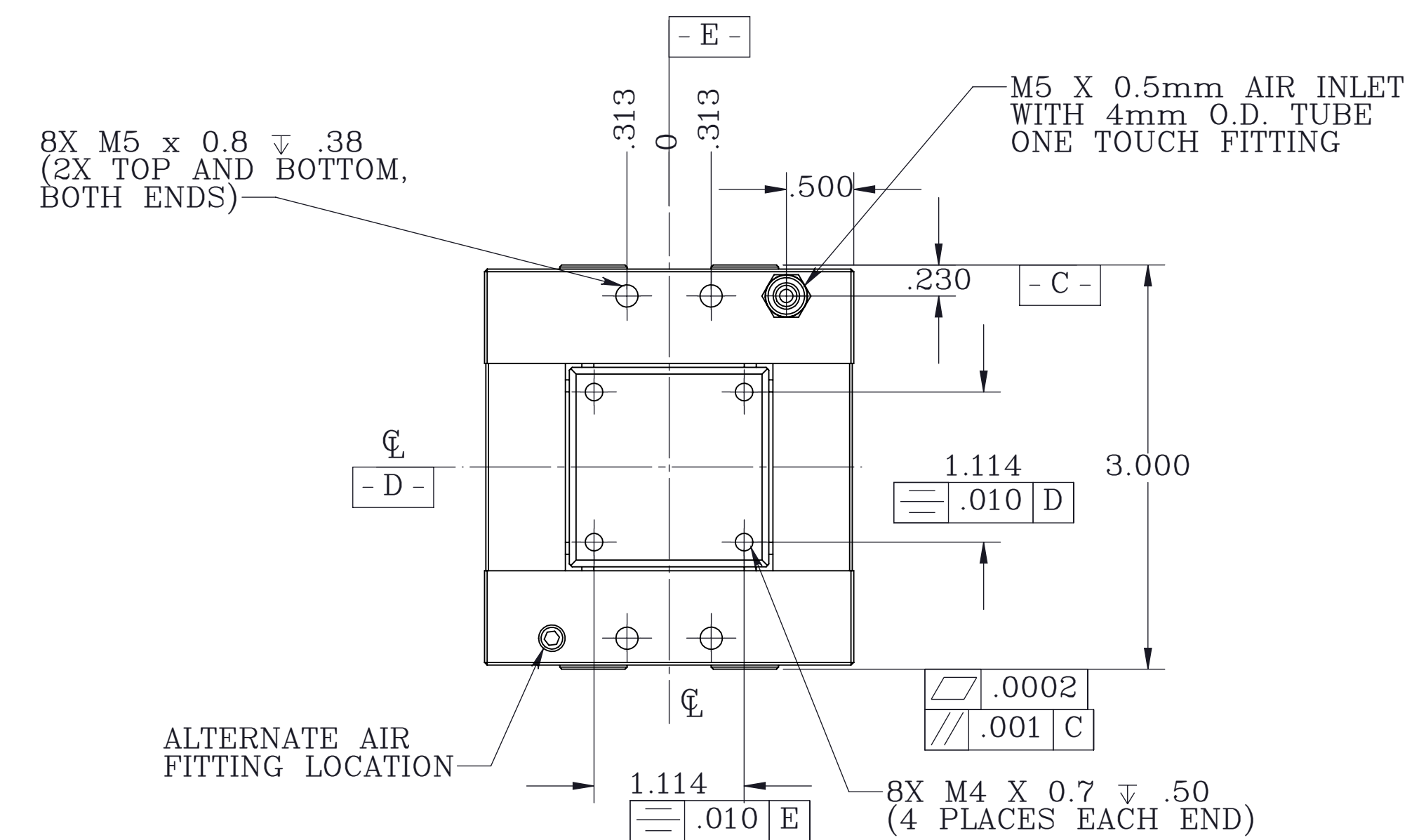
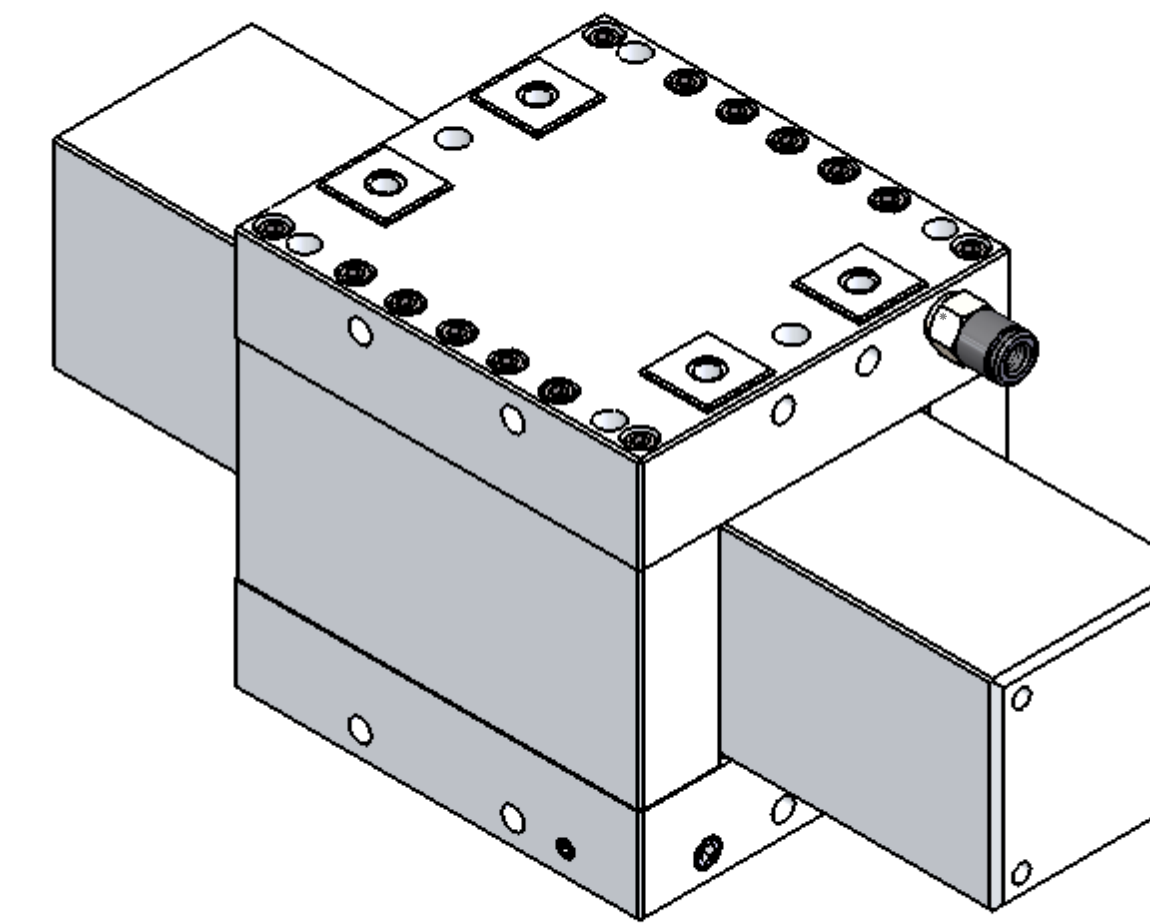
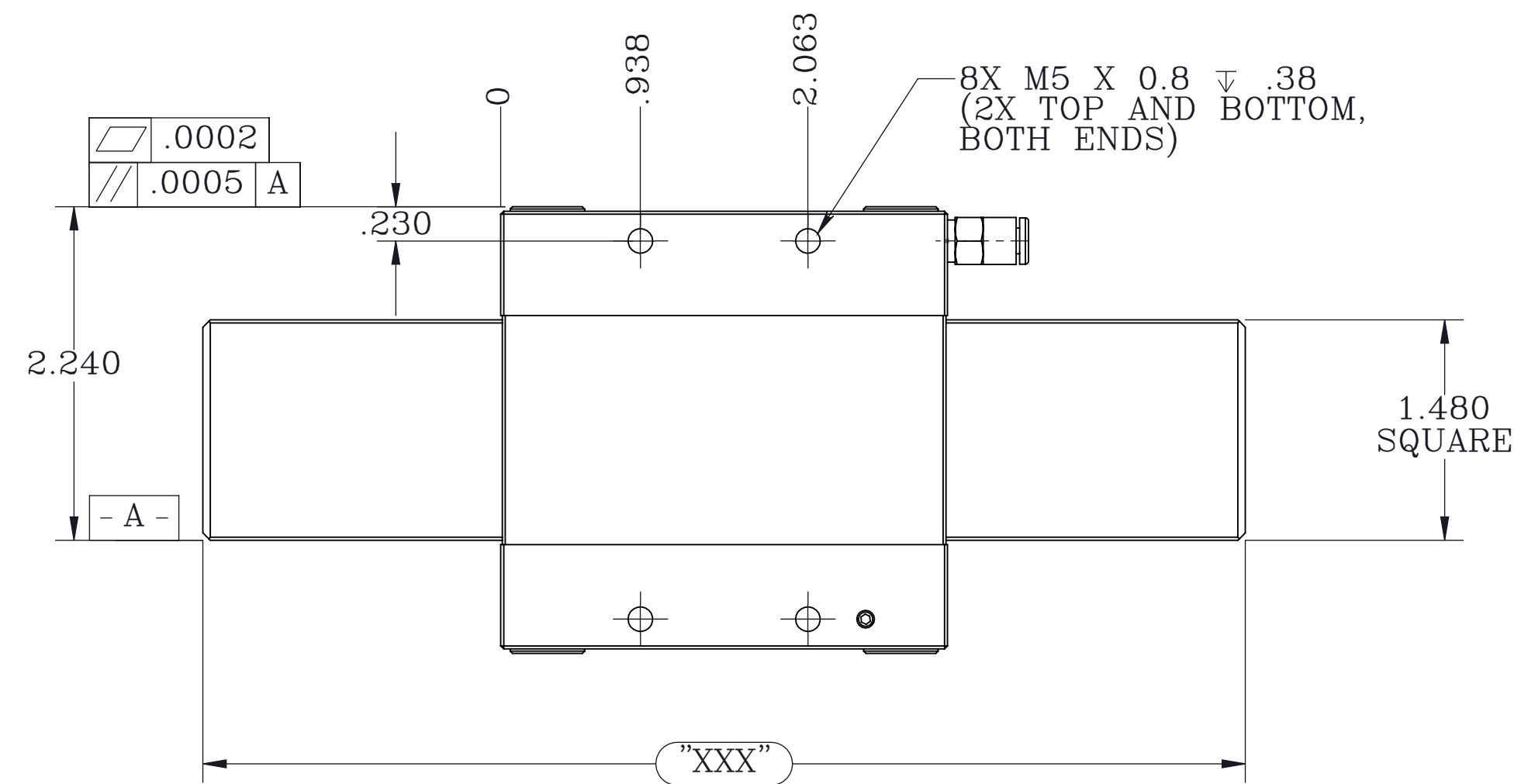
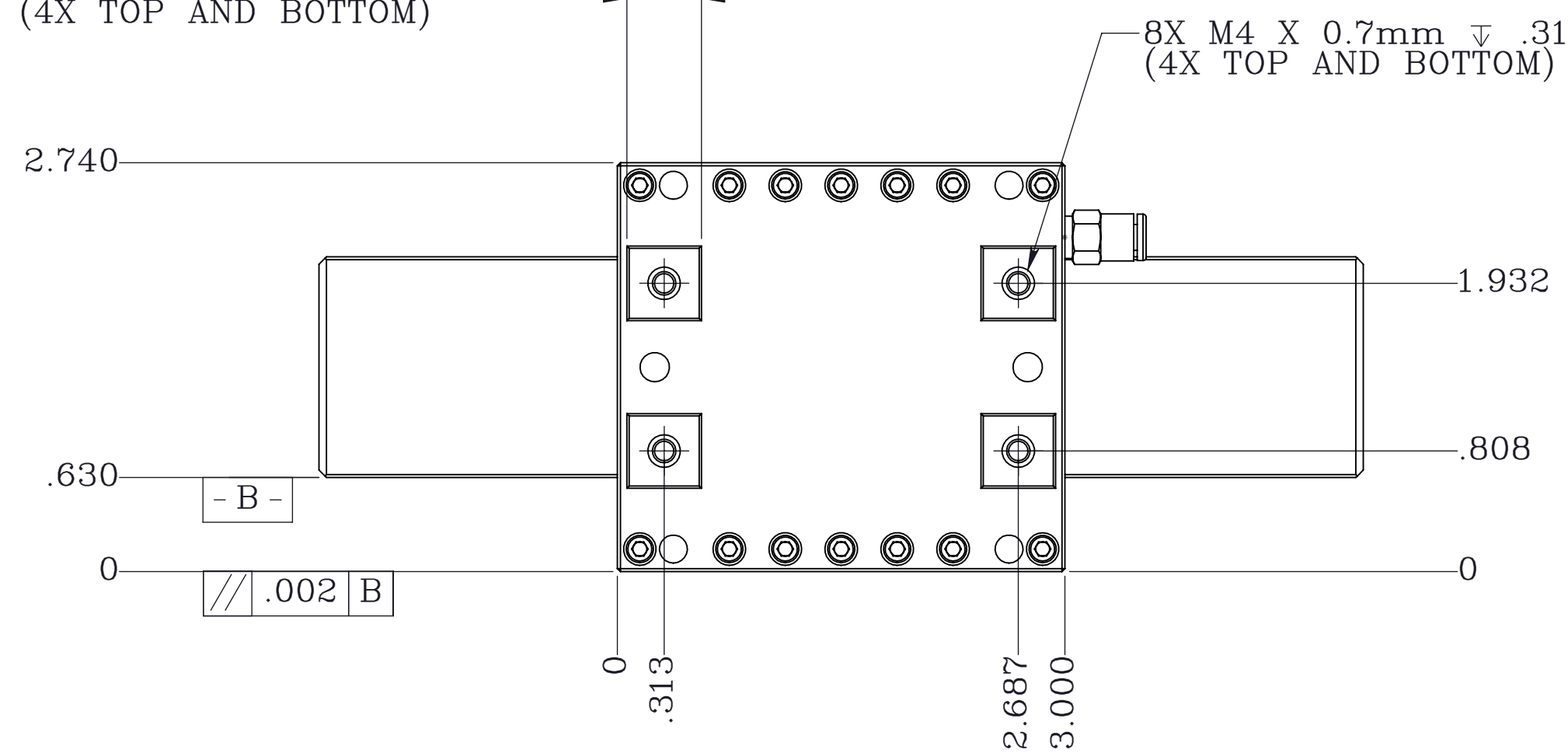

NOTES:

- MATERIAL AND FINISH:  
HOUSINGS AND GUIDE BAR: BLACK ANODIZED ALUMINUM  
BEARINGS: POROUS CARBON
- "XXX" IN mm DENOTES THE LAST 3 DIGITS OF THE ASSEMBLY PART NUMBER AS LISTED IN THE CHART ABOVE

PROPRIETARY ITEM:  
THIS DRAWING CONTAINS INFORMATION PROPRIETARY TO NEW WAY MACHINE COMPONENTS, INC. ANY REPRODUCTION, DISCLOSURE OR USE OF THIS DRAWING OR THE INFORMATION CONTAINED HEREIN IS EXPRESSLY PROHIBITED EXCEPT AS NEW WAY MAY OTHERWISE AGREE TO IN WRITING. ALL RIGHTS RESERVED BY NEW WAY MACHINE COMPONENTS, INC.

TOLERANCES UNLESS OTHERWISE SPECIFIED		TITLE: 1.5 X 1.5 AIR SLIDE ASSEMBLY WITH 3" STAGE		NEWWAY <sup>®</sup>	
ANGLES: $\frac{1}{2}^{\circ}$	DECMALS: xx .010	DRAWN: CSS	DATE: 4/14/14	MATERIAL: SEE NOTES	
FRACTIONS: 1/64	SURFACE ROUGHNESS: 63 RMS MAX.	CHECKED:	DATE:	HEAT TREAT: SEE NOTES	
BREAK ALL SHARP EDGES .005-.020		SCALE: 1:1	SHT. 1 OF 1	FINISH: SEE NOTES	
		USED ON:		EWO. NO.:	
				DWG. NO. S40-03075-038XXX-C	
				REV.:	