

SECTION A-A

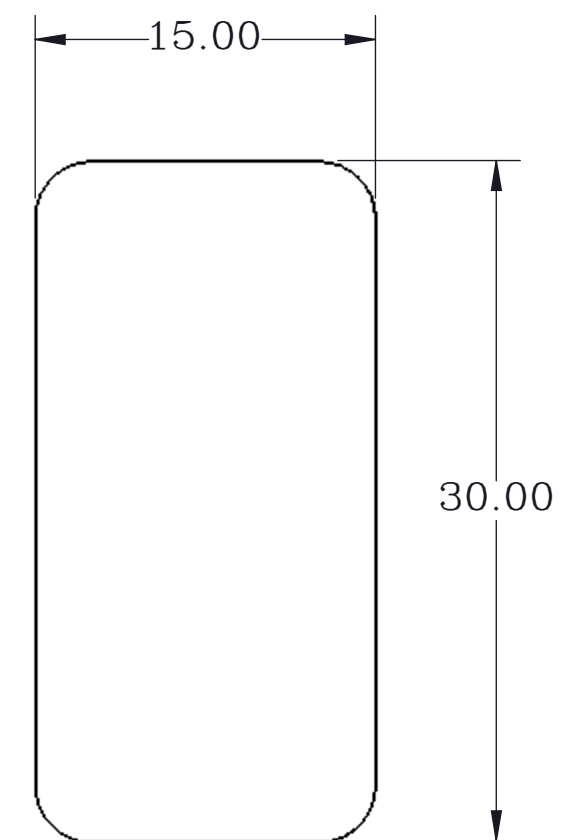

NOTES:

- ALL DIMENSIONS ARE REFERENCE UNLESS OTHERWISE NOTED
- ALL DIMENSIONS ARE IN MILLIMETERS (MM)
- TOOLING BALL IS REFERENCE ONLY, (NOT INCLUDED)
- RADIUS XXX MIN:30MM MAX:150MM

PROPRIETARY ITEM:

THIS DRAWING CONTAINS INFORMATION PROPRIETARY TO NEW WAY MACHINE COMPONENTS, INC. ANY REPRODUCTION, DISCLOSURE, OR USE OF THIS DRAWING OR THE INFORMATION CONTAINED HEREIN IS EXPRESSLY PROHIBITED EXCEPT AS NEW WAY MAY OTHERWISE AGREE TO IN WRITING. ALL RIGHTS RESERVED BY NEW WAY MACHINE COMPONENTS, INC.

TOLERANCES UNLESS OTHERWISE SPECIFIED ANGLES $\pm 1/2^\circ$ DECIMALS .XX $\pm .25$ MM DECIMALS .XXX $\pm .13$ MM SURFACE ROUGHNESS $1.6 \sqrt{\text{RMS MAX.}}$ BREAK ALL SHARP EDGES $.13-.5$ MM	TITLE: 15MM X 30MM RADIAL BEARING			
	DRAWN: JHA	DATE: 11/8/06		
	CHECKED:	DATE:	HEAT TREAT:	EWO. NO.
	SCALE: 3:1	SHT. 1 OF 1	FINISH: SEE NOTES	DWG. NO. S3215LXXX